

Polaris 3600

In-Line Print & Apply

A product of *Nortek Automation, Inc.*



The Polaris 3600 is a conveyor-fed system that precisely places labels onto printed circuit boards. Labels can be preprinted or printed on-demand. The base system is designed for one label per panel. Optional board stops can be added for multiple labels.

NORTEK AUTOMATION INC.

Providing Solutions Through Automation Since 1985

WORLD HEADQUARTERS

15632 Producer Lane, Huntington Beach, CA 92649 USA

Phone (714)895-8590*Fax (714)895-8039

www.nortekautomation.com

Copyright ©1996-2001 Nortek Automation, Inc. All rights reserved.

SALES & SERVICE

Texas, Illinois, California, U.K., Switzerland, Taiwan, Japan, & Hong Kong

Features

Versatile:

- Print on demand
- 600 dpi printer
- Print barcodes, graphics & symbols
- Automatic serialization
- Automatic date coding
- SMEMA compatible conveyor
- Conveyor width adjustable to 10"

Productive:

- Simple design for maximum up-time
- Easy to maintain
- High throughput capability

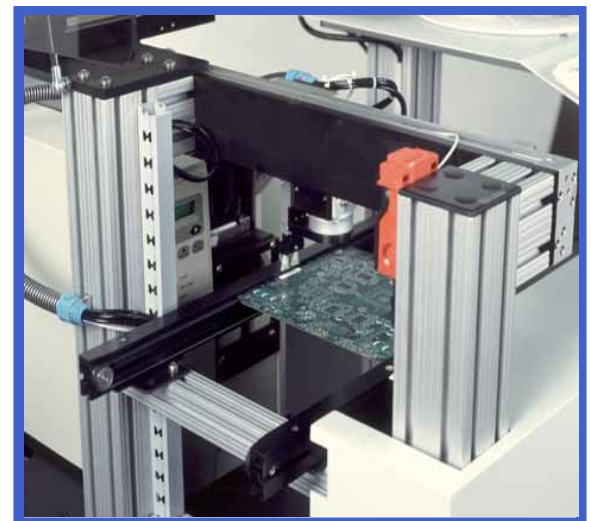

Options

- Board Stacker and De Stacker
- 90° Tamp Head Rotation
- Expanded Conveyor Width to 18"
- Network Interface
- Label Server
- Desktop Label Creation & Management Software

FACILITY REQUIREMENTS

POLARIS 3600

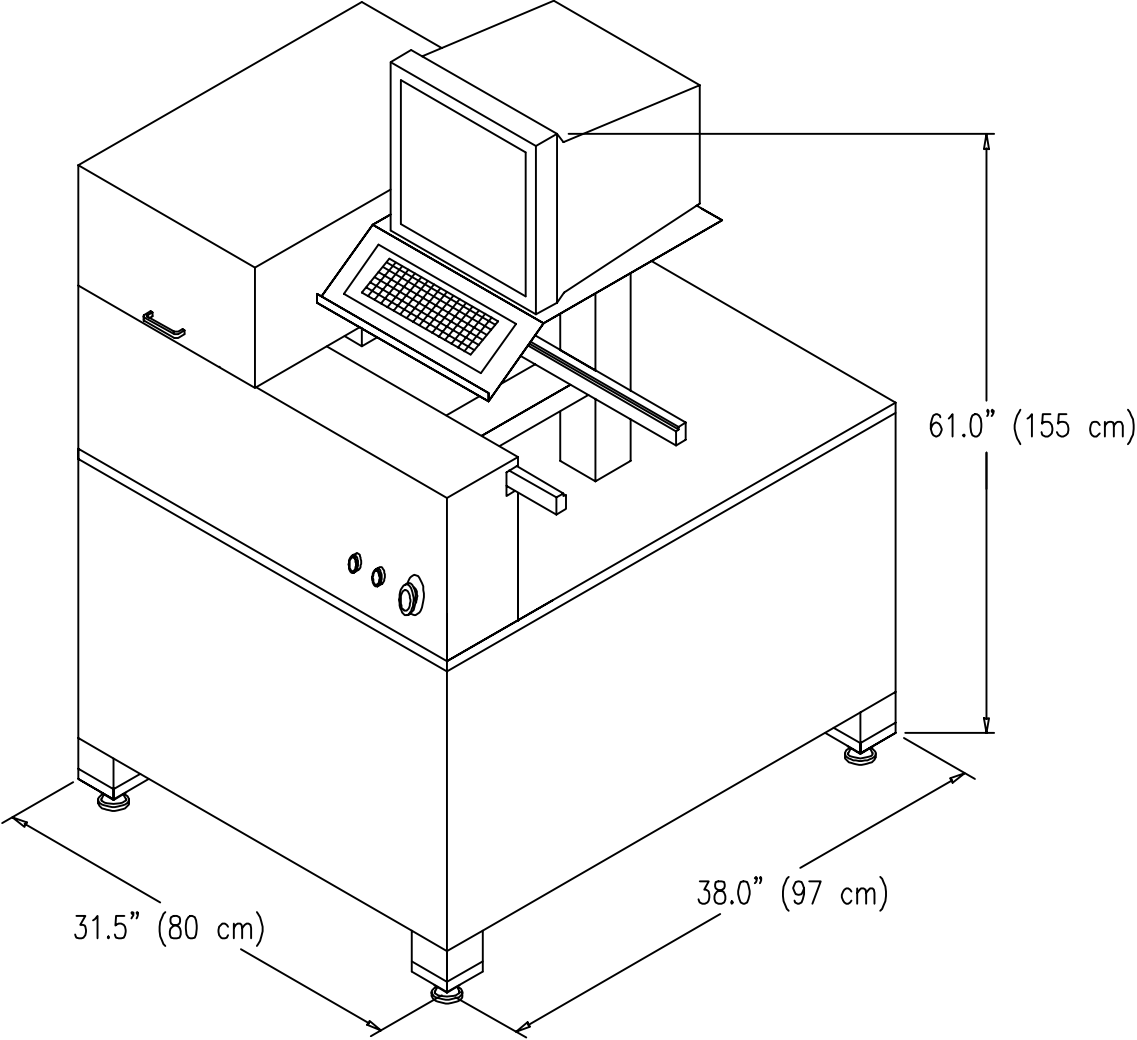

Power:	110 VAC, 10 AMP, Single Phase
Air Fitting:	¼" Plug, Industrial Design Quick Disconnect (MIL-C-4109)
Air Consumption:	10 SCFM (285 Nl/min) Clean, dry air @ 100 PSI (6.9 Bar)
Weight:	250 pounds, 113 kg.

NORTEK AUTOMATION, INC.
www.nortekautomation.com

Copyright (c) 2001
All Rights Reserved